

TOWER INSTALLATION GUIDE

This tower is built from bottom up wards.

After the foundation has been casted with the anchor bolts in. Start by placing all 4 legs on the plinths and hand fasten the anchor bolts to the legs.

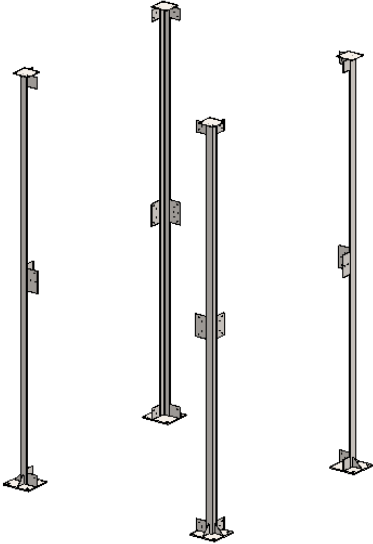

Once legs are in place, hand fasten all the bottom bracing followed by the horizontal bracing.

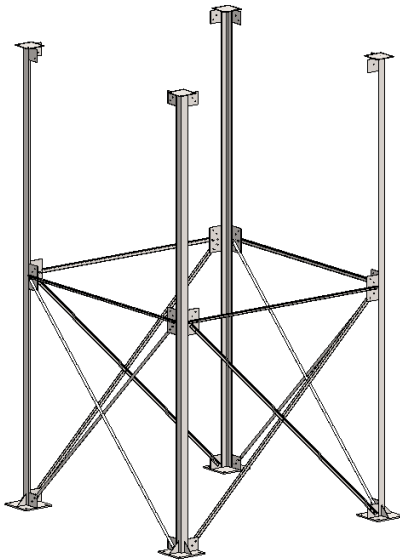

Then hand fasten all the top bracing. Make use of scaffolding etc.

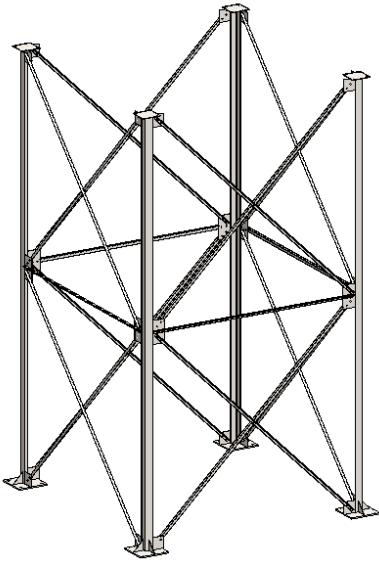

When all bracing is in place and fastened. Secure the anchor bolts tightly followed by all the bracing bolts.

Place the girder beam assemblies (main carrier beams) to the top of the legs and tighten. Keeping in mind of where the ladder position will be.

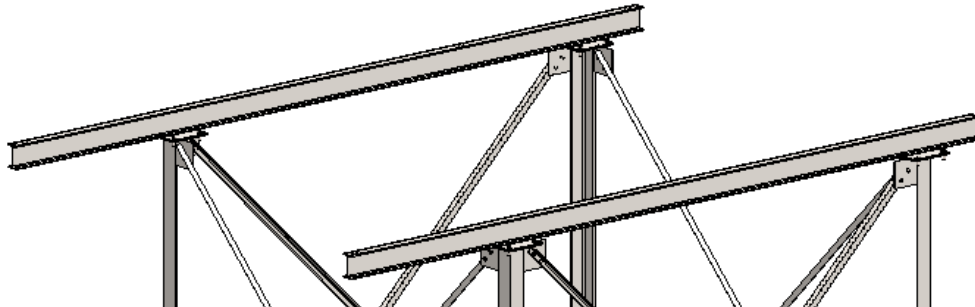

Place and secure the joist beams to the girder beams. *Keeping in mind of where the ladder position will be.

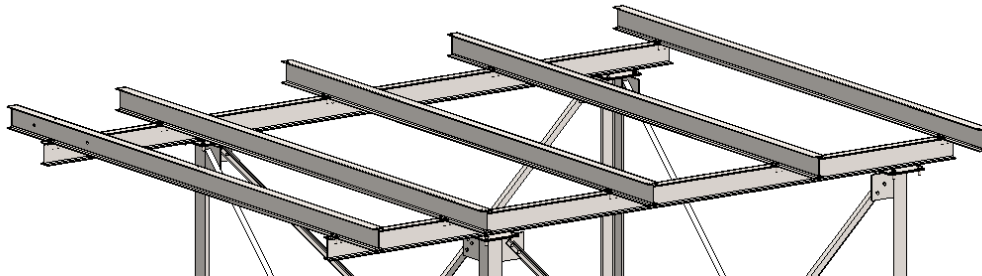

Continue placing the kick rails and grating for the walk way.

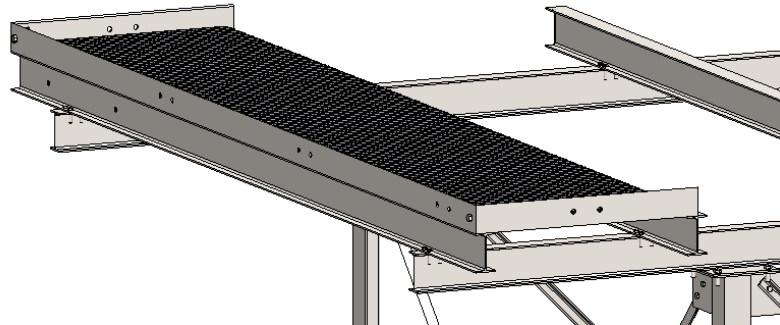

At this time the ladder can be constructed and mounted to the foundation and to the tower.

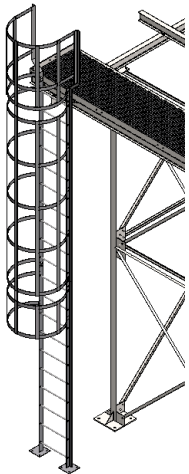

The railing for the walkway also be bolted onto the walkway.

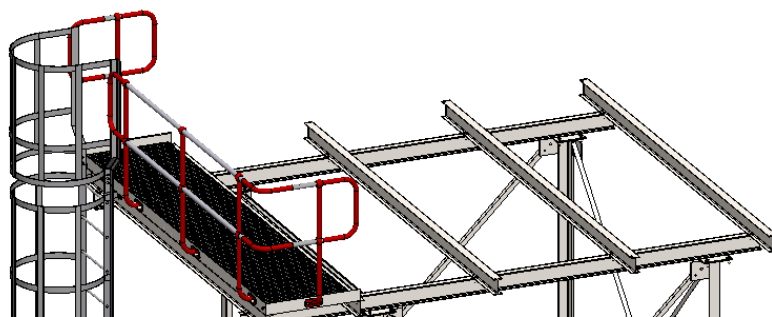

Once all bolts are in place and properly tightened. The tank installation can begin.

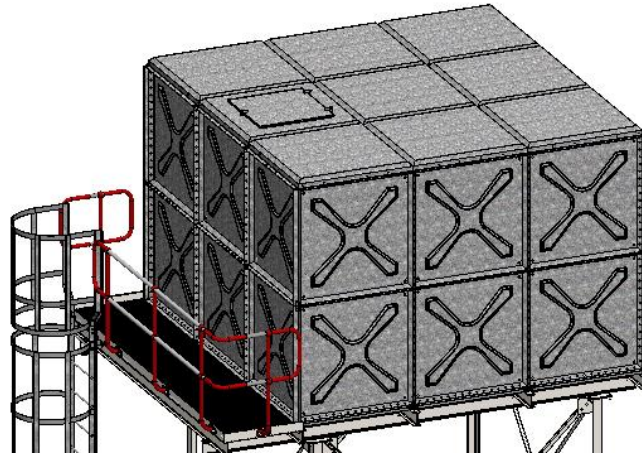

After the tank is installed, mount the tank ladder as well as the top cage.

